

Perché una distinta Tecnica ?

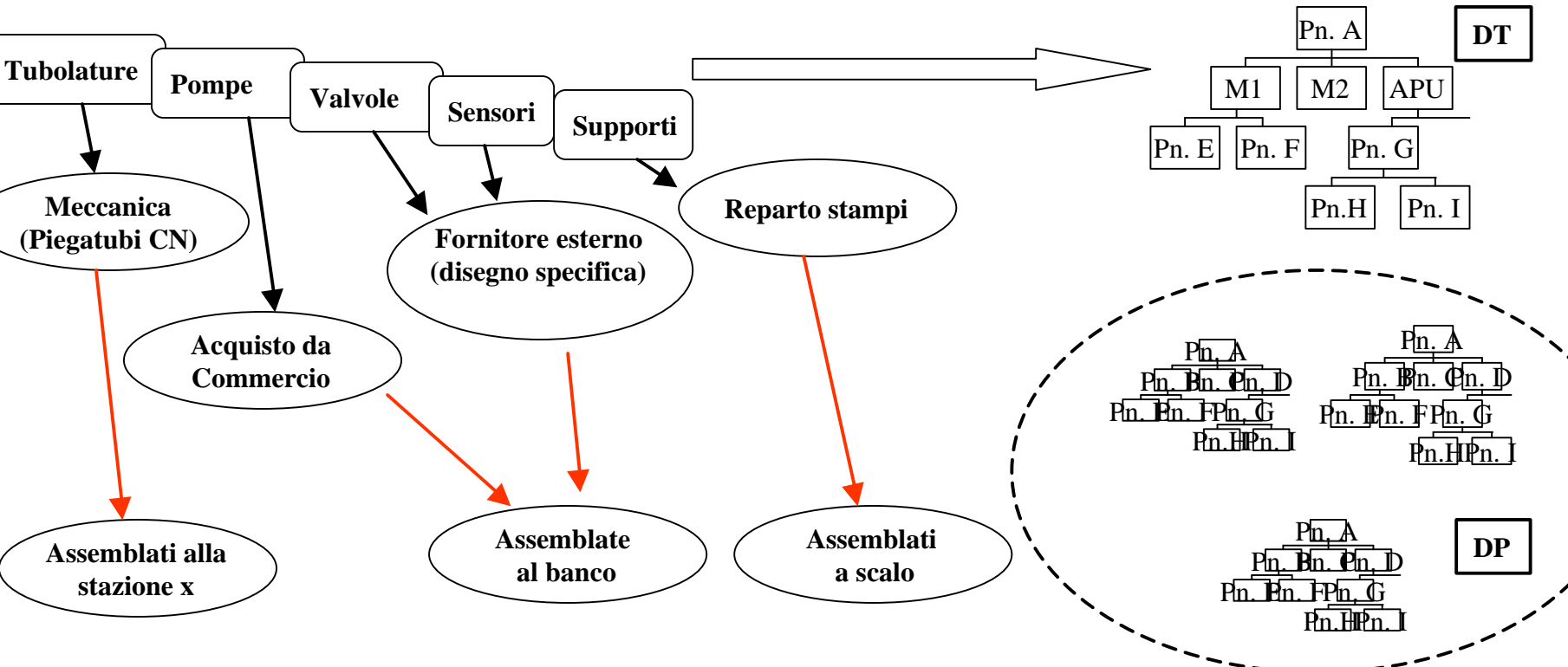

L'ossatura iniziale e la crescita della distinta tecnica

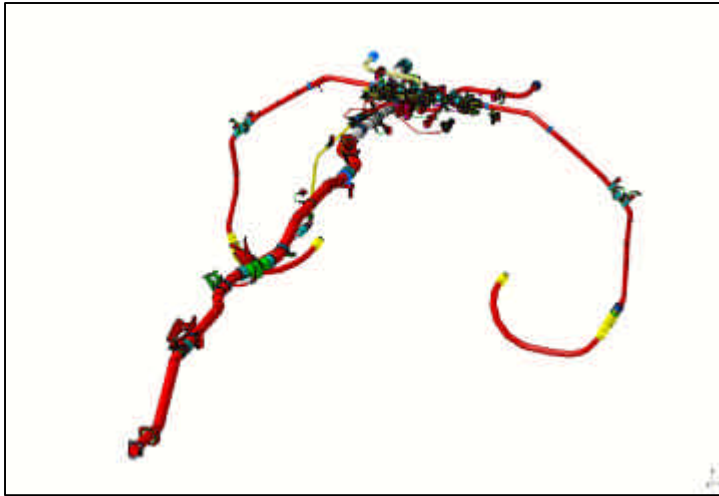
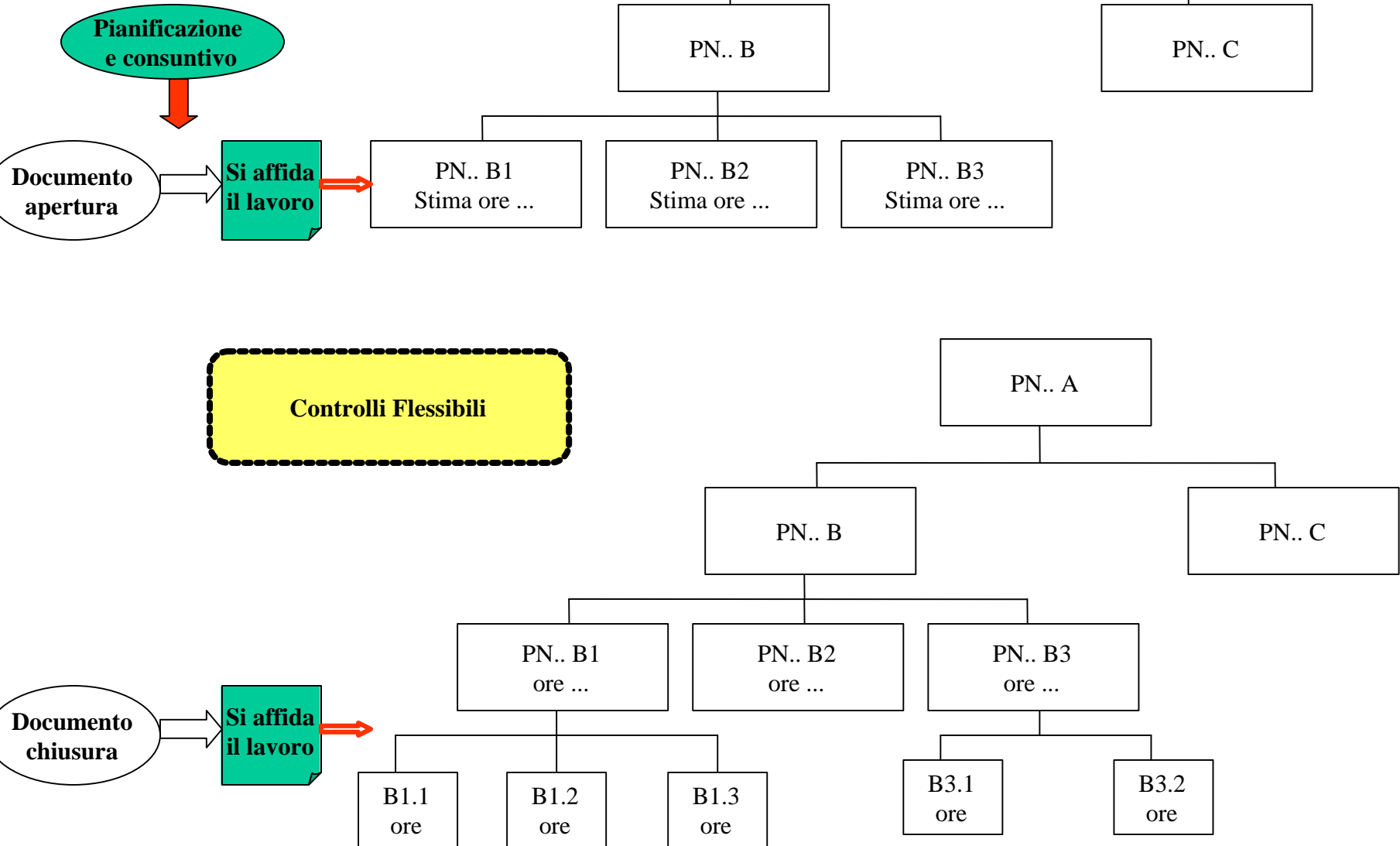

La configurazione del prodotto



Gli oggetti prodotti sono in configurazione unica, al più le distinte, come gli oggetti prodotti, possono cambiare da una certa data in poi (validità per data)

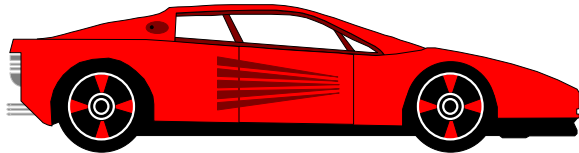

La distinta tecnica (se esiste) include tutte le predisposizioni per i vari optionals, in modo da renderli componibili direttamente all'atto della vendita al cliente.

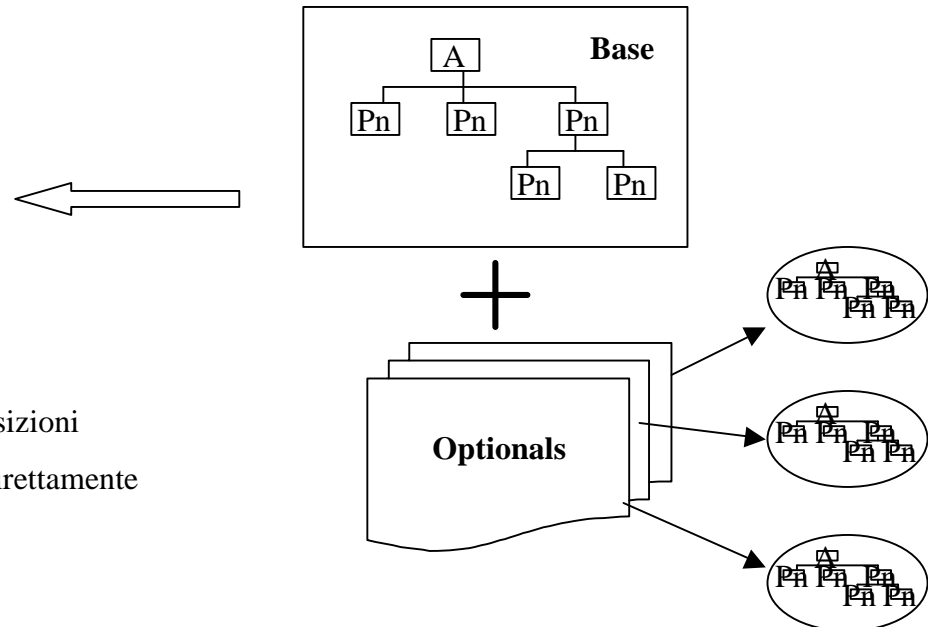
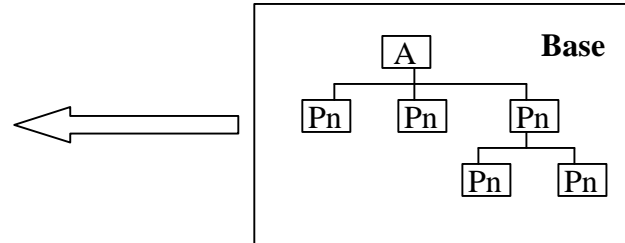

Configurazione

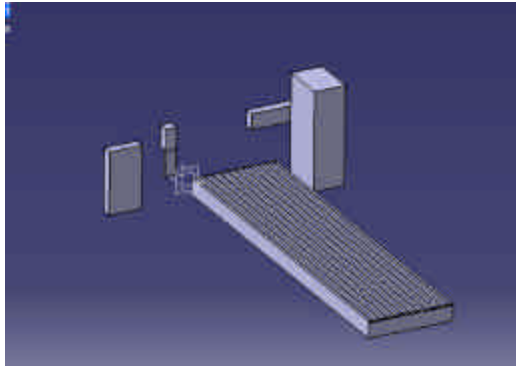

Insieme dei bancali

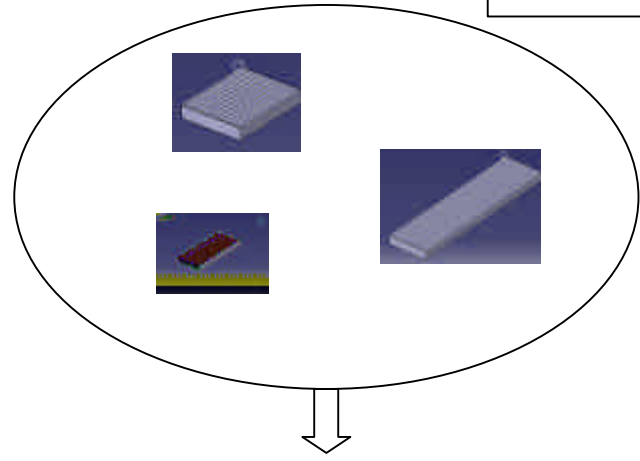

Vincolo, con la lunghezza delle guide del montante, la possibilità di montare o meno una tavola girevole, ecc

Insieme delle tavole

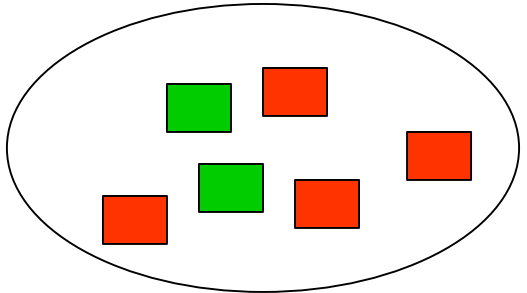
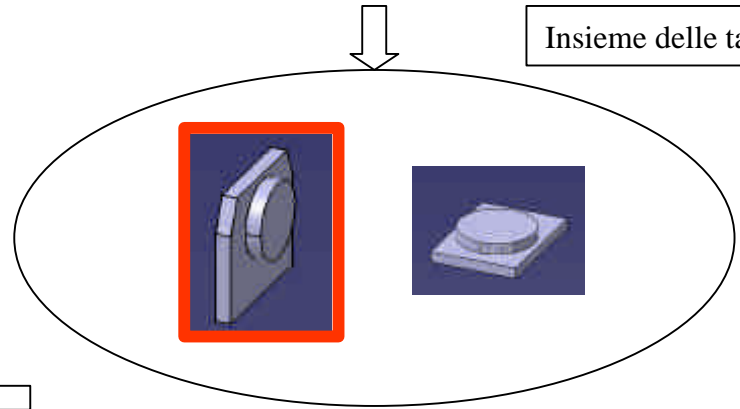

Insieme degli armadi

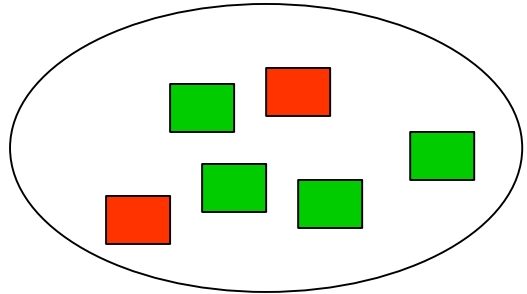

Insieme dei controlli



La configurazione del prodotto e la Manutenzione

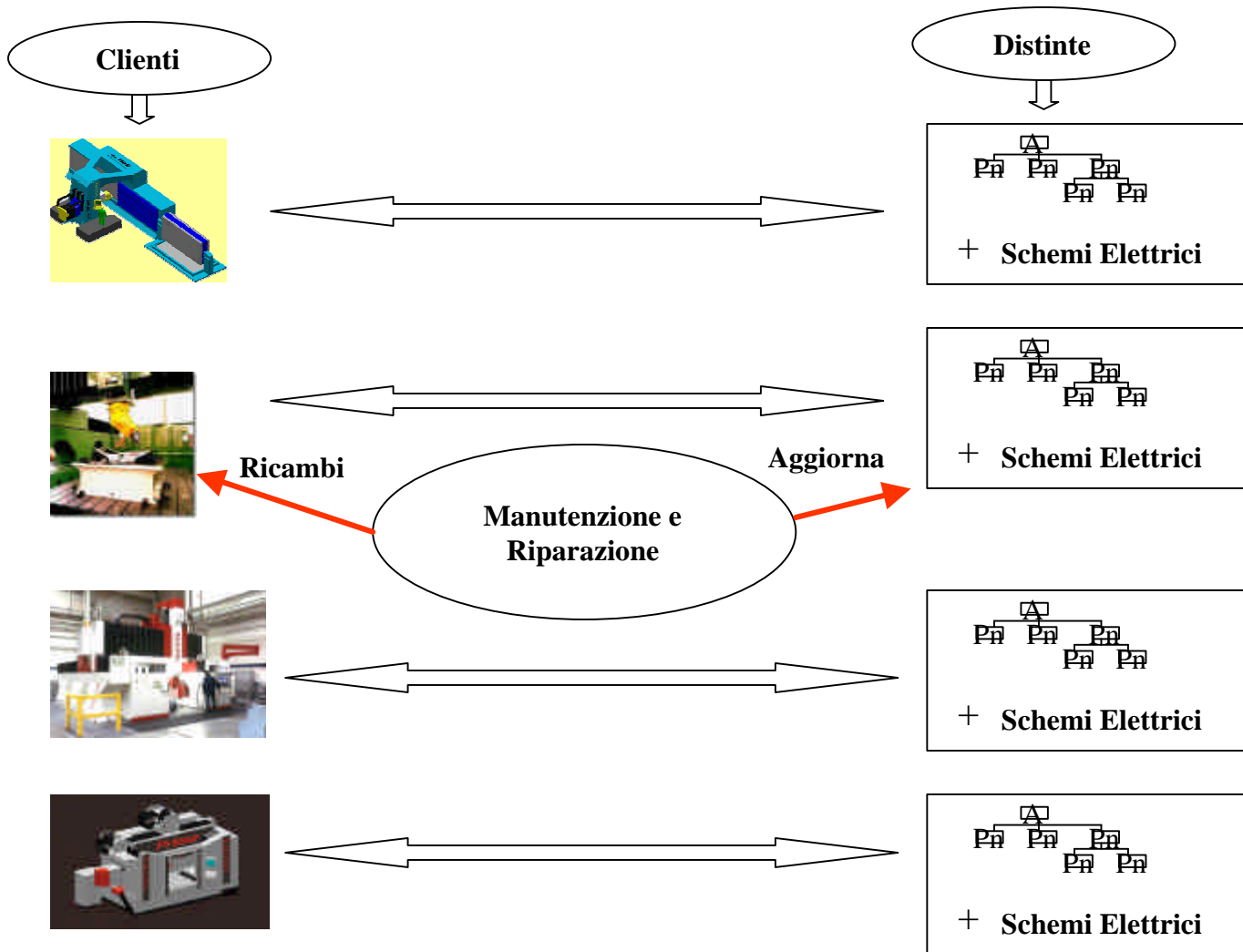

Effettività

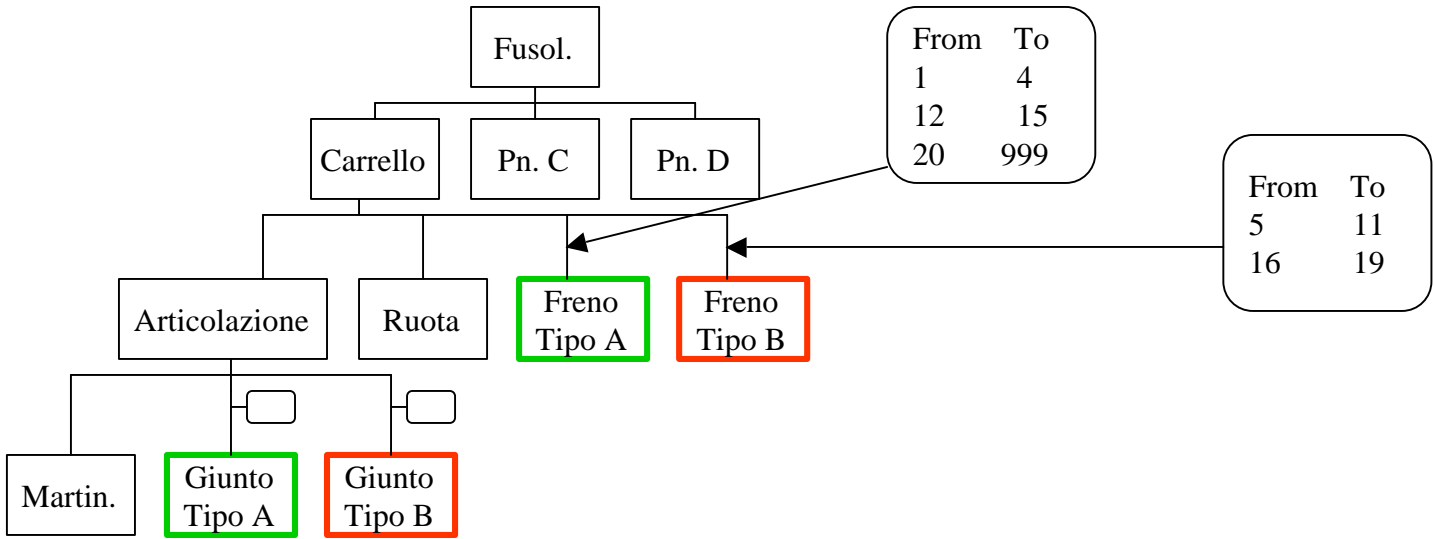
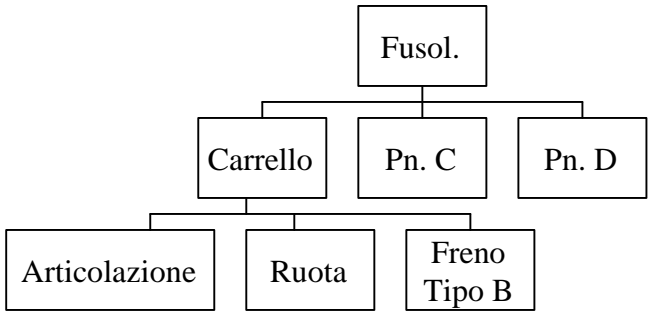
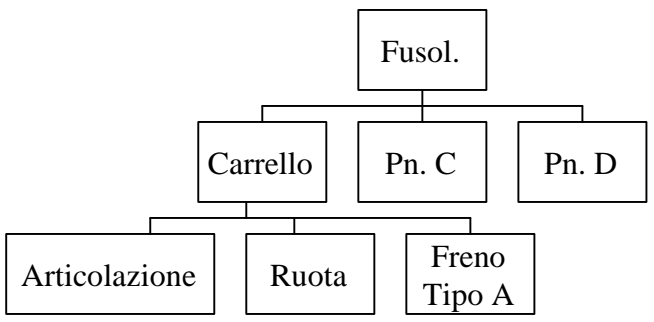
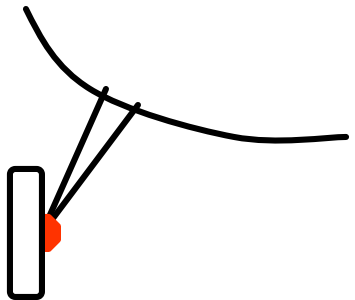
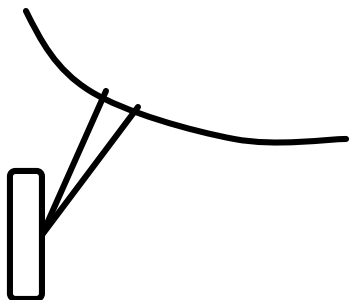

Oggetti Prodotti e gestiti

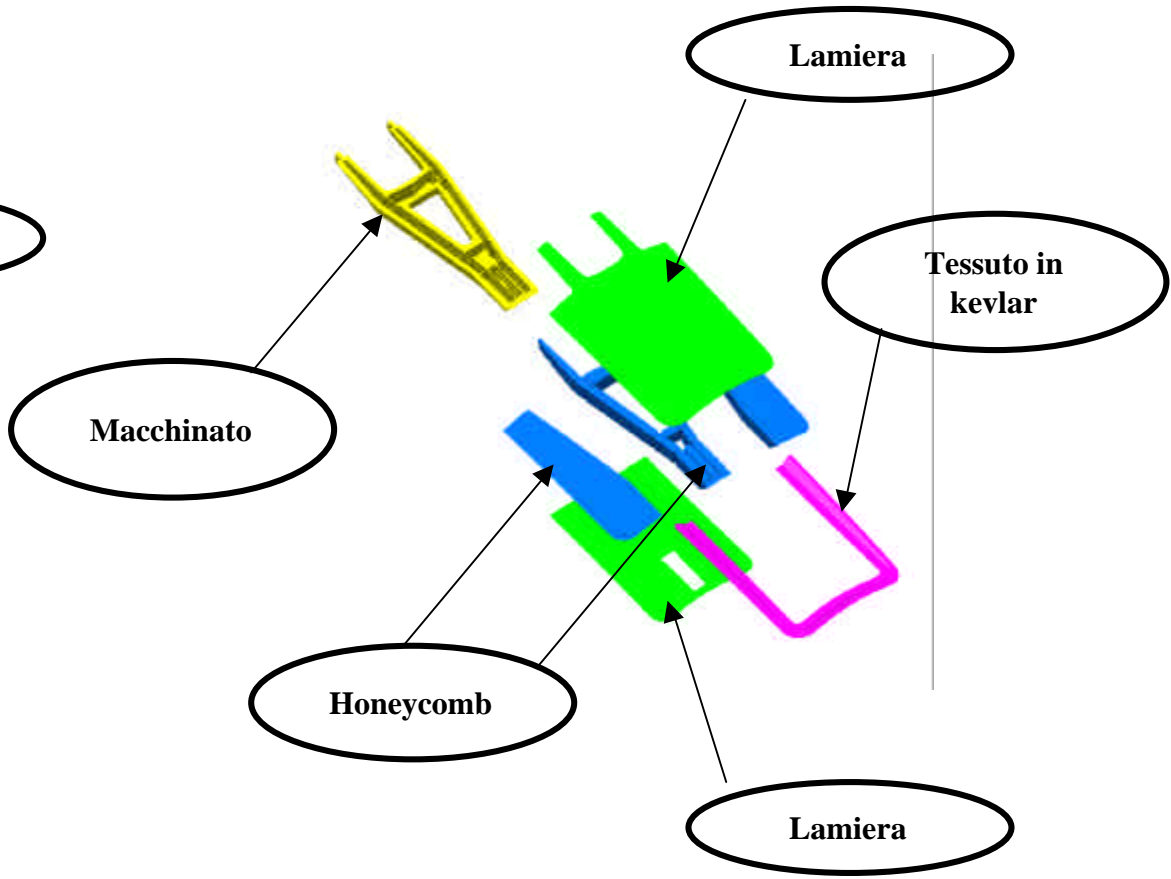
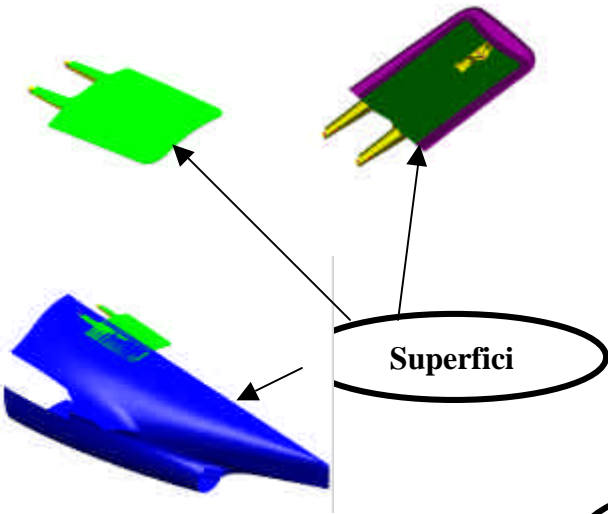

Part_Number

Codici superfici
utilizzate

Modelli Solidi 3D

Disegni dei singoli
fogli di kevlar

Sviluppi per
le lamiere

Disegni dei PN
con uno o più fogli

Assiemi di
primo livello

Assiemi generali

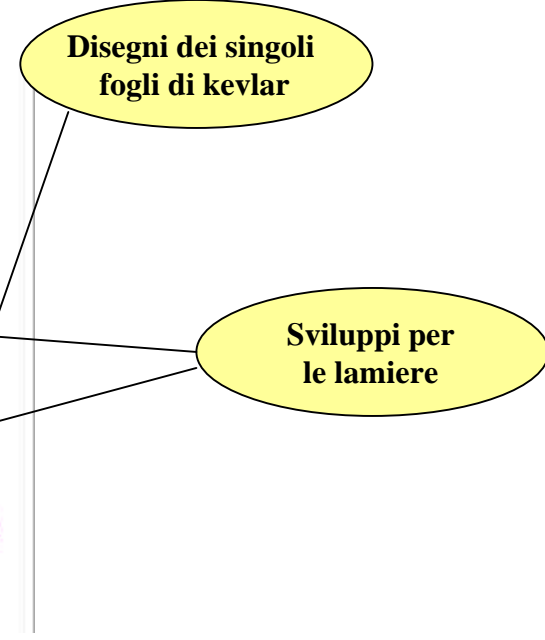
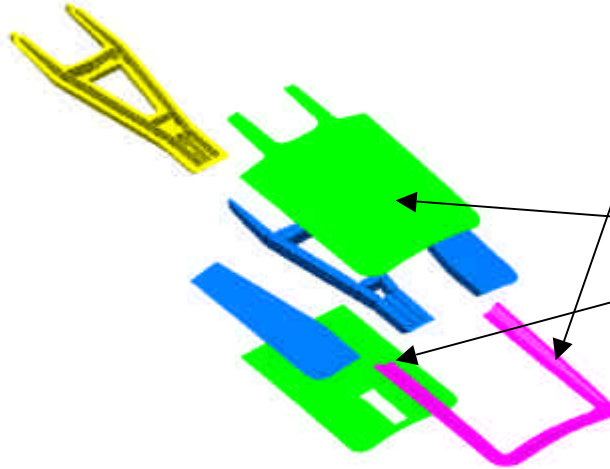

Dalla DT al DBT
Superfici

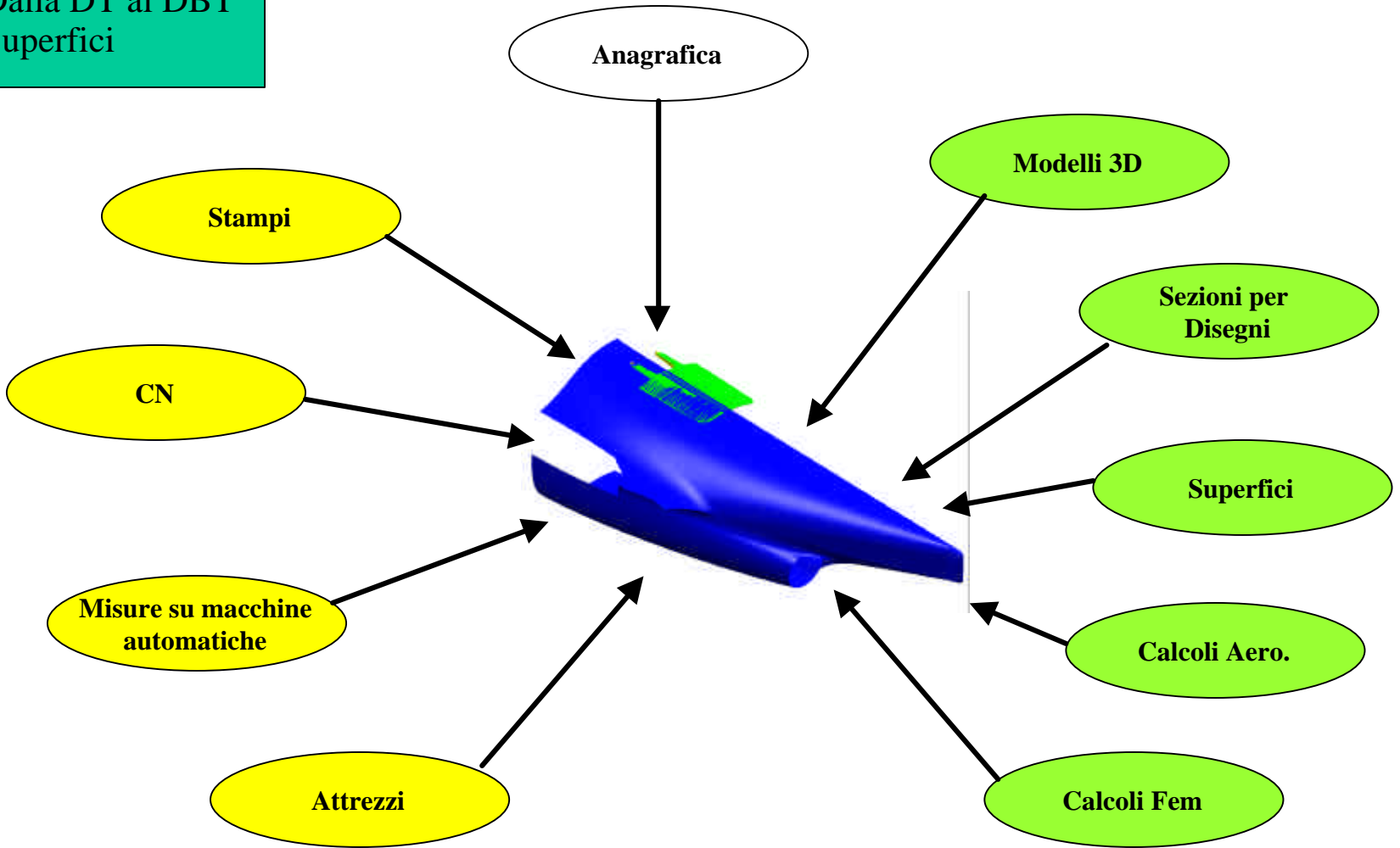

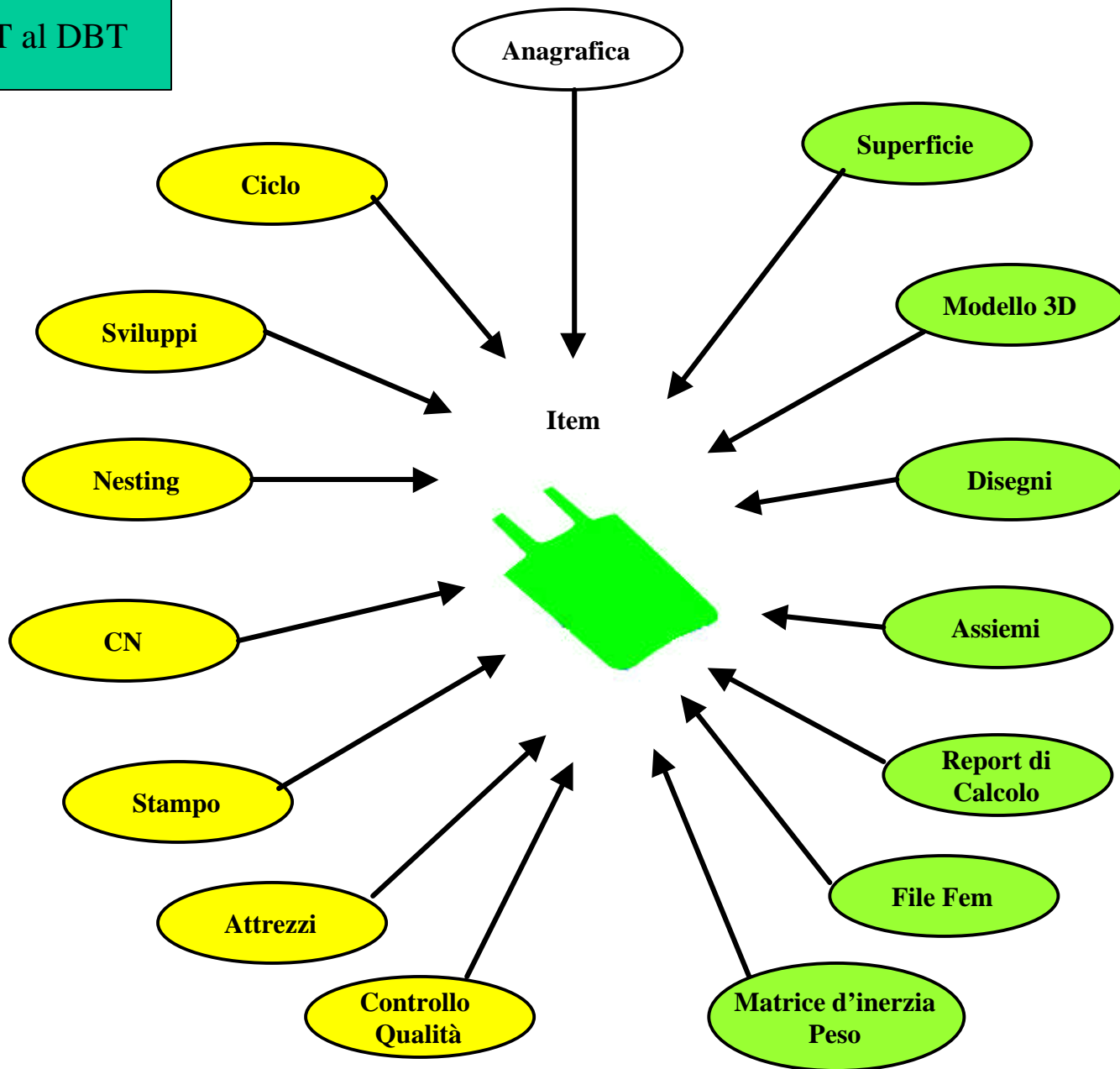

**Dalla DT al DBT :
Pesi e centraggi**

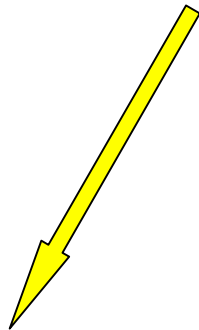
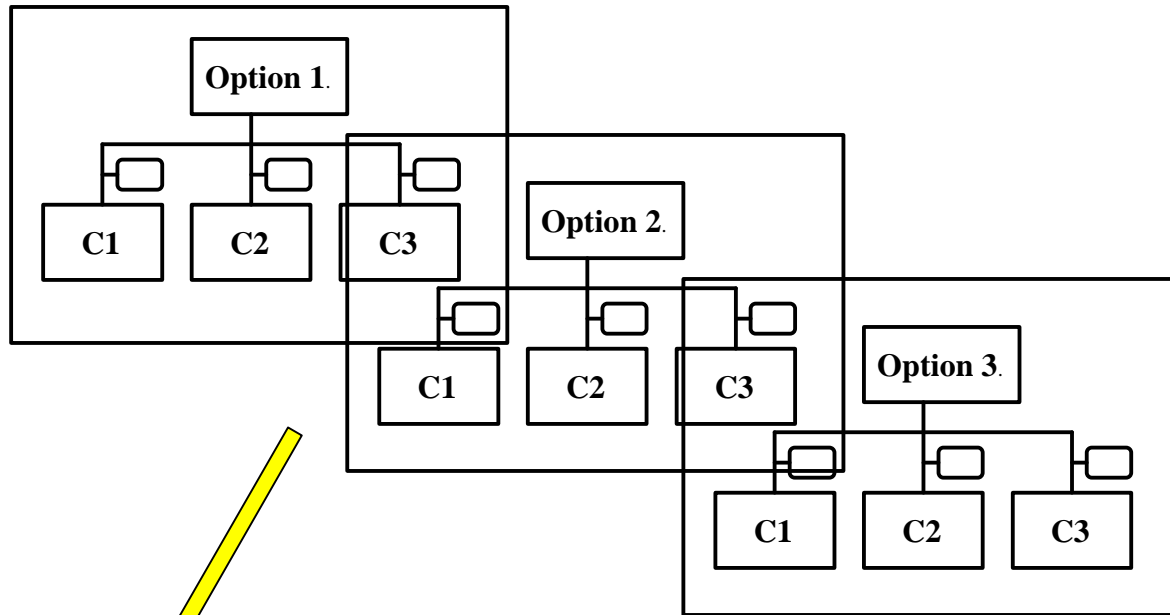
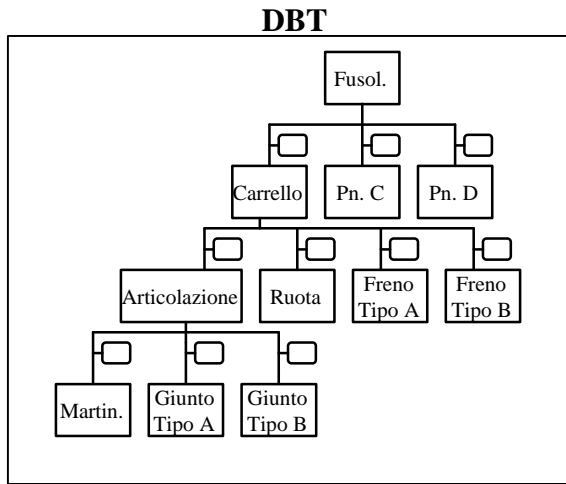

Configurazione Velivolo

Opzione Armamento



W

Jxx	Jxy	Jxz	Xg
Jyx	Jyy	Jyz	Yg
Jzx	Jzy	Jzz	Zg
0	0	0	1

Le distinte operative

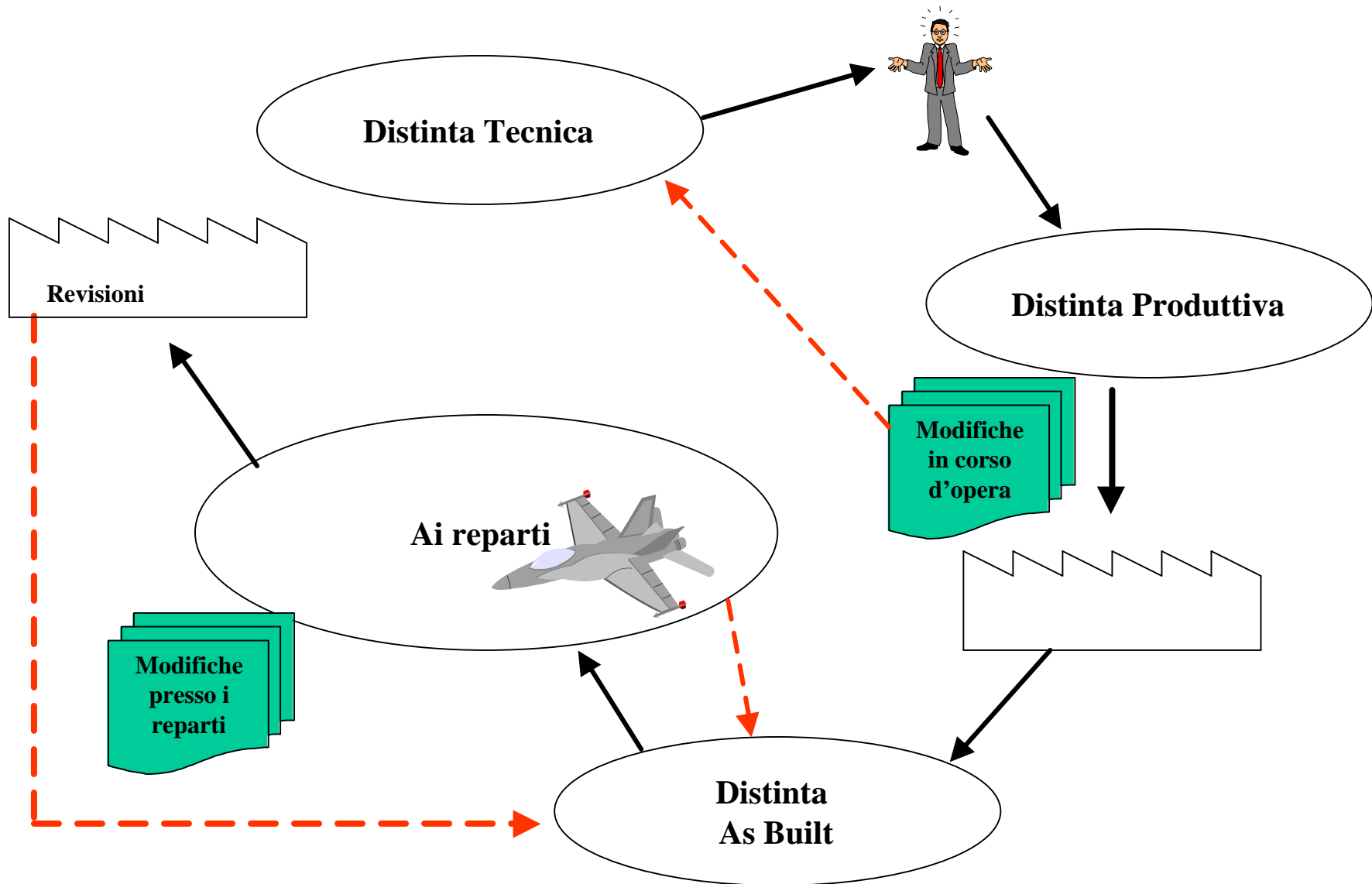

DBT Architettura Fisica

